

AUSTRALIAN NATIONAL UNIVERSITY
Department of Engineering

ENGN6612/4612 Digital Signal Processing and Control
 Problem Set #8 Filter Structures

Q1

A digital filter defined by the transfer function:-

$$(a) H(z) = \frac{1}{3} \{1 + z^{-1} + z^{-2}\}$$

$$(b) H(z) = \frac{2}{1 - 3z^{-1} + z^{-2}}$$

For each $H(z)$:

- Identify the filter type (FIR or IIR).
- Find the difference equation.
- Draw the block diagram representation of the filter in Direct-Form I.

Q2

A digital filter defined by the transfer function:-

$$H(z) = \frac{1}{1 + \frac{1}{4}z^{-1} - \frac{1}{8}z^{-2}}$$

Draw the block diagram representation of the filter in

- Direct-Form I.
- Cascade Form.
- Parallel Form.

Q3

A digital filter defined by the transfer function:-

$$(a) H(z) = \frac{1 - \frac{7}{4}z^{-1} - \frac{1}{2}z^{-2}}{1 + \frac{1}{4}z^{-1} - \frac{1}{8}z^{-2}}$$

$$(b) H(z) = \frac{1 - 6z^{-1} + 8z^{-2}}{1 - \frac{2}{3}z^{-1} + \frac{1}{9}z^{-2}}$$

For each $H(z)$, draw the block diagram representation of the filter in Direct-Form II.

Q4

A digital filter is shown in the block diagram shown below:

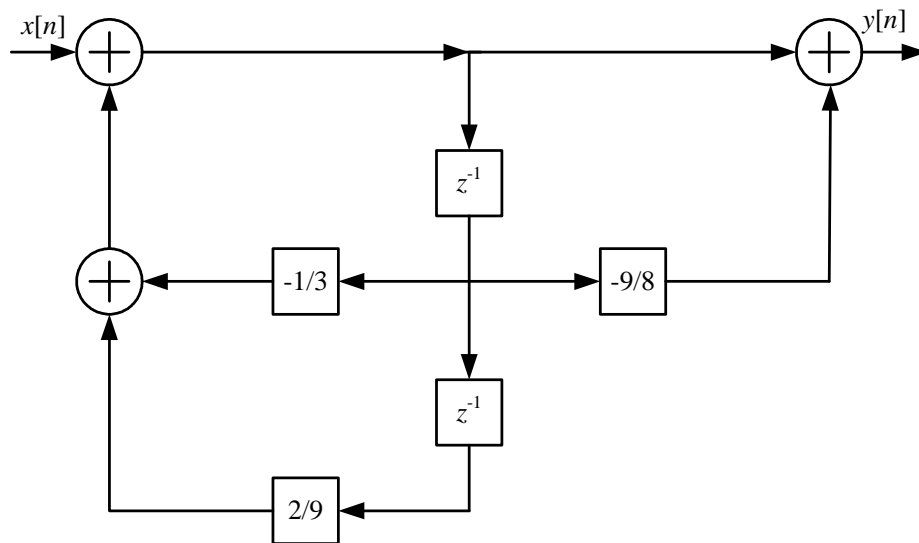

Figure 1: Question 4.

For the given filter, find the difference equation. (challenge problem)